Applying Shielded Metal Arc Welding (SMAW) Techniques

Unit: Mechanical Systems and Technology

Problem Area: Metal Fabrication

Lesson: Applying Shielded Metal Arc Welding (SMAW) Techniques

■ **Student Learning Objectives.** Instruction in this lesson should result in students achieving the following objectives:

- 1 Explain the fundamentals and developments of shielded metal arc welding.**
- 2 Describe how to select shielded metal arc welding equipment and supplies.**
- 3 Explain how to prepare metal for welding.**
- 4 Describe the procedures and techniques for shielded metal arc welding.**
- 5 Identify the safety practices that should be observed when working with shielded metal arc welding.**

■ **List of Resources.** The following resources may be useful in teaching this lesson:

Burkybile, Carl, and Stanley R. Burke. *Modern Agricultural Mechanics*, Third Edition. Upper Saddle River, NJ: Prentice Hall Interstate, 2006.

Phipps, Lloyd J., and Carl Reynolds. *Mechanics in Agriculture*. Danville, IL: Interstate Publishers, Inc., 1992.

Safety in the Shop (VAS 3022a). University of Illinois, Urbana, IL: ITCS Instructional Materials.

Shielded Metal-Arc Welding (VAS 3004a). University of Illinois, Urbana, IL: ITCS Instructional Materials.

■ List of Equipment, Tools, Supplies, and Facilities

- ✓ Writing surface
- ✓ Overhead projector
- ✓ Transparencies from attached masters
- ✓ Copies of student lab sheet
- ✓ Arc welders and accessories
- ✓ Steel

■ Terms. The following terms are presented in this lesson (shown in bold italics):

- ▶ Alternating current
- ▶ Amperage
- ▶ Arc length
- ▶ Arc welding
- ▶ Conductor
- ▶ Crater
- ▶ Direct current
- ▶ Duty cycle
- ▶ Electricity
- ▶ Electrode
- ▶ Electrons
- ▶ Fillet weld
- ▶ Groove weld
- ▶ Padding
- ▶ Polarity
- ▶ Resistance
- ▶ Shielded metal arc welding
- ▶ Surface welds
- ▶ Voltage
- ▶ Weaving
- ▶ Weld root
- ▶ Welder
- ▶ Welding
- ▶ Weldor

■ Interest Approach. Use an interest approach that will prepare the students for the lesson. Teachers often develop approaches for their unique class and student situations. A possible approach is included here.

Show students a broken machinery part and ask how the broken piece might be repaired. Lead a class discussion concerning the repair of the part or

replacement of it. If the part is to be repaired, what skills will be necessary to complete the job?

SUMMARY OF CONTENT AND TEACHING STRATEGIES

Objective 1: Explain the fundamentals and developments of shielded metal arc welding.

Anticipated Problem: What are the fundamentals and developments of shielded metal arc welding?

- I. There are basic fundamentals of welding that must be understood.
 - A. **Welding** is the melting, flowing together, and freezing of metals under controlled conditions.
 1. **Arc welding** uses electricity to heat and melt the metal.
 2. A **Welder** is the person doing the welding.
 3. A **Welder** is the machine doing the welding.
 4. **Shielded metal arc welding** is welding where fusion is produced by heating with an arc between a consumable stick electrode and the work piece.
 5. An **electrode** is a bare metal rod which is usually coated with chemical compounds called flux. The flux coatings burn in the intense heat and form a blanket of smoke and gas that shields the weld puddle from the air.
 - B. A basic understanding of electrical terms is necessary to fully understand shielded metal arc welding.
 1. **Electricity** is the flow of tiny particles called electrons through a conductor.
 2. **Electrons** are negatively charged particles.
 3. A **conductor** allows the flow of electrons.
 4. **Voltage** is a measure of electrical pressure.
 5. Most welders operate on a 220 volt source. A welder changes or transforms the 220 volt pressure to a much lower pressure at the electrode, usually between 15 and 25 volts.
 6. **Amperage** is a measure of electrical current flowing through a circuit and is an indication of the heat being produced. The amount of current available is determined by the amperage setting on the welder.
 7. **Polarity** is the direction the current is flowing.
 8. **Resistance** is the opposition to the flow of current in a circuit. Resistance is what causes the electric energy to be transformed into heat.

9. When electricity is conducted through a conductor, the movement of the electric energy heats the conductor due to the resistance of the conductor to the flow of electric current through it.
 10. The greater the flow of current through a conductor, the greater the resistance to it, and the greater the heat generated (the higher the amperage setting, the greater the heat produced).
 11. When electrical current alternates or reverses the direction of electron flow it is called **alternating current** (AC).
 12. The arc is extinguished every half-cycle as the current passes through zero, usually at the rate of 120 times per second.
 13. Electron flow in one direction is called **direct current** (DC) which is either straight polarity (DCSP) or reverse polarity (DCRP)
 - a. When the electrons flow from the electrode to the work piece it is straight polarity.
 - b. When the electrons flow from workpiece to the electrode it is reverse polarity.
- C. The art of welding is an ancient one but the science of shielded metal arc welding is relatively new.
1. 1801—English scientist discovered that an electric current would form an arc when forced across a gap.
 2. 1881—A French inventor used the carbon arc.
 3. 1887—A Russian improved on the carbon arc and patented the process.
 4. 1887—Another Russian discovered that a bare metal rod would melt off by the heat of the arc and act as a filler metal in a weld.
 5. 1889—An American experimented with the metallic arc and received a patent. A bare electrode was difficult to use and resulted in a weld which was porous, brittle, and not as strong as the base metal.
 6. 1910—A Swede found that welds were stronger and easier to make when a chemical coating was put on the metal electrode. The coating was called flux because it cleaned the metal and aided in mixing the filler metal with the base metal, however it was difficult to apply.
 7. 1927—Mass production method developed to apply the flux to the bare metal rod.

Students can use the suggested resources to aid in understanding the content of the objective. Use TM-A, TM-B, and TM-C as visual material for lecture and discussion. An alternative approach is to transfer the information from the transparency masters to a multimedia presentation.

Objective 2: Describe how to select shielded metal arc welding equipment and supplies.

Anticipated Problem: How are equipment and supplies selected for use with shielded metal arc welding?

- II. There are several different types of equipment and supplies to choose from.
 - A. Welding machines are classified in several different ways.
 1. One common way is by the type of output current produced by the welder, AC, DC, or AC/DC.
 2. Another way to classify welders is by their service.
 - a. Limited input welders provide satisfactory operation and are fairly inexpensive to operate. Their cost is about a dollar per ampere of output.
 - b. Limited service welders are used where lower cost is desired, because the operation is quite intermittent.
 - c. Industrial welders have a high duty cycle, but their price is much higher.
 3. Power source is another way welders are classified.
 - a. An electric motor driven welder is self-contained and requires three-phase power. Electric power runs the motor which turns a generator to produce DC welding current.
 - b. An internal combustion engine drives a generator that produces the power for the welder to run.
 - c. Line voltage welders run on the power supplied by the power company.
 4. **Duty cycle** is the percentage of a 10 minute period that a welder can operate at a given current setting and is another way to classify welders. A welder with a 60 percent duty cycle can be operated safely for six minutes of a ten minute cycle repeated indefinitely.
 5. When buying a new welder, consider only one made by a well-known manufacturer and distributed by a reliable dealer.
 - a. Check the nameplate to see if the welder is National Electrical Manufacturers Association (NEMA) rated and approved and listed by Underwriters Laboratories (UL).
 - b. Compare prices of welders, equal capacity, and the kinds of accessories available.
 - c. Read the guarantee carefully and ask questions.
 - B. There are several other pieces of equipment and supplies necessary in order to operate the shield metal arc welder.
 1. Two cables, No. 2 gauge, are required.
 2. The electrode holder grips the electrode during welding and should be completely insulated, have a spring-grip release, and jaws that hold rods in 60, 90, 120, and 180 degree positions in relation to the handle.
 3. The ground clamp is fastened to the work or to the welding table.

4. The chipping hammer, with a straight peen, and straight cone with a spiral wire-grip, is necessary to remove slag from the weld bead.
5. A wire brush is used to clean dirt, rust, and slag from metal.
6. Pliers are needed for handling hot metal. Welding gloves will be ruined by touching hot metal because moisture will be drawn-out and the leather will harden and shrink.
7. Safety glasses or goggles are required to protect the operator's eyes when chipping hot slag, and grinding or cleaning metal for joint preparation.
8. Full gauntlet leather gloves should always be worn.
9. Upper body protection is necessary to protect against rays, heat, spatter, and slag while welding.
10. A head shield is necessary for protection from the rays of the electric arc, and the heat and spatter of the molten metal.
11. Use only filter lenses that are clearly labeled with standard shade numbers and be sure they meet the specifications of the welding you are performing. A No. 10 lens meets applications up to 200 amps.
12. Electrodes convey electric current from the welding machine into a hot arc between its tip and the metal being welded.
13. Electrodes are covered with flux. The flux provides four important functions.
 - a. Flux protects the molten metal from the atmosphere.
 - b. The flux-covering burns in the intense heat of the arc, forming a blanket or shield of gas around the bead. Air contains oxygen and nitrogen which would combine with the metal to cause it to be brittle and weak.
 - c. Flux mixes with the weld metal, floating the impurities to the top in the form of slag. Slag covers the bead to protect it from the air and slow the rate of solidification and cooling.
 - d. Flux stabilizes the arc. After the arc is started, current flows across the gap between the end of the electrode and the work.
14. Current does not jump the gap but is conducted by a mass of ionized gas.
15. Gas is produced when chemical substances are vaporized by the heat of the arc.
16. There are two classifications of electrodes. The American Welding Society (AWS) and the American Society for Testing Materials (ASTM) have set up standard numerical classifications for most electrodes.
17. Every electrode has been assigned a specific symbol, such as E7014.
 - a. The "E" indicates the electrode is used for electric welding.
 - b. The first two digits of a four digit number indicate tensile strength in thousands of pounds per square inch.
18. An E7014 electrode produces a weld with 70,000 psi of tensile strength.
19. An E6011 electrode produces a weld with 60,000 psi of tensile strength.
 - a. If the number has five digits, the first three digits indicate tensile strength.
 - b. The next to last digit indicates welding position for which the electrode is recommended.

- c. The last digit indicates the operating characteristics of the electrode.
- 20. The National Electrical Manufacturers Association (NEMA) has adopted color marking for some classes.

Students can use the suggested resources to aid in understanding the content of the objective.

Objective 3: Explain how to prepare metal for welding.

Anticipated Problem: How is metal prepared for welding?

- III. One of the most important and most often neglected parts of the welding job is preparation of the metal for welding.
 - A. The metal must be free of dirt, grease, rust, paint, or other impurities which may combine with a molten weld bead and cause it to be weakened. Metal should be cleaned by grinding, brushing, filing, or cutting before welding.
 - B. Preparing the correct type of joint for each kind of metal is crucial to securing strong welded structures.
 - 1. The basic types of joints are the butt, lap, tee, corner, and edge. These joints may be applied to the different types of welds: fillet, groove, plug, slot, and surface.
 - 2. A tee weld is a type of fillet weld. The **fillet weld** has two surfaces at right angles, and the bead is triangular in shape.
 - 3. The **groove weld** is a weld made in a groove between the two pieces of metal to be joined.
 - 4. The plug and slot welds are used to join pieces that overlap. The welds are placed in plug or slot holes. These types of welds commonly take the place of rivets in welded structures.
 - 5. **Surface welds** are beads deposited on a metal surface for the purpose of building up the base metal.
 - 6. The square butt joint is used on metal sections no thicker than $\frac{3}{16}$ inch. This joint is strong in tension loads but not good for repeated loads and impact forces.
 - 7. The single V butt joint is often used on plate steel $\frac{3}{8}$ inch to $\frac{3}{4}$ inch in thickness. This joint is strong in loads with tension forces but weak in loads that bend at the weld root. The **weld root** is the bottom of the weld groove opposite the weld face.
 - 8. The single-bevel butt joint is used on metals from $\frac{1}{8}$ inch to $\frac{1}{2}$ inch in thickness and the bevel is 45 degrees.
 - 9. The double V butt joint is excellent for all load conditions and is often used on metal sections over $\frac{3}{4}$ inch in thickness.
 - 10. The lap joint is a type of fillet weld. Its strength depends on the size of weld bead.

11. The single lap joint is one of the stronger weld joints. It is used on metal up to $\frac{1}{2}$ inch in thickness.
12. The double lap joint is almost as strong as the base metal.
13. The T-joint is a fillet weld and can be used on metals up to $\frac{1}{2}$ inch in thickness. It can withstand strong longitudinal shear forces. The T-joint can be square, beveled, or double beveled.
14. The corner joints can be flush, half-open, or full-open
 - a. The flush corner joint is primarily used on sheet metal.
 - b. The half-open joint can be used on metals heavier than sheet metal and for joints that will not have large fatigue or impact loads. This joint can be welded from one side.
 - c. The full-open corner joint is used for the metals that will carry heavy loads and can withstand large fatigue and impact loads and can be welded on both sides.
15. Edge joints are used for metals less than $\frac{1}{4}$ inch in thickness and can only sustain light load applications.

Students can use the suggested resources to aid in understanding the content of the objective. Use TM-D, TM-E, TM-F, TM-G and TM-H as visual material to reinforce common welds, major types of welds, basic welding positions, and common joints. An alternative approach is to transfer the information from the transparency masters to a multimedia presentation.

Objective 4: Describe the procedures and techniques for shielded metal arc welding.

Anticipated Problem: What are the procedures and techniques for shielded metal arc welding

- IV. Good welds can be attributed to correct selection and manipulation of the electrode and welding current.
 - A. The following skills must be performed in unison to achieve a weld of acceptable quality.
 1. The proper amperage setting for any welding job is necessary to get good penetration with minimum spatter. Correct amperage can be identified somewhat by sound.
 - a. When the amperage is correct, a sharp crackling sound can be heard.
 - b. A humming sound will indicate too low an amperage setting and the deposited electrode will pile up, leaving a narrow, high bead that has poor penetration and little strength.
 - c. A popping sound will indicate too high an amperage setting and the bead will be flat with excessive spatter. The electrode will become red hot, and the metal along the edge of the bead will be undercut.

2. Correct amp setting depends on the thickness of the base metal and the diameter of the electrode.
 3. Learning to maintain the correct arc length for the electrode you are using is necessary in order to be successful.
 - a. **Arc length** is the distance from the tip of the bare end of the electrode to the base metal.
 - b. Arc length is equal to the diameter of the bare end of the electrode.
 4. The correct angle of the electrode will depend on the type of weld that is to be completed. Hold the electrode at a 90 degree angle to the work as viewed from the end of the two plates being joined, and 5 to 15 degrees in the direction of travel.
 5. Correct speed of travel affects the amount of electrode deposited and the uniformity of the bead. It should produce a bead that is 1.5 to 2 times the diameter of the bare end of the electrode.
- B. Following proper procedures when preparing to weld and striking the arc will develop confidence in your abilities.
1. Prepare the work area so that everything is ready and convenient before you start.
 2. Make a final check to see that flammable materials are out of the way and that unnecessary tools are not lying around.
 3. Be sure the machine is turned off.
 4. Set the machine to the desired amperage.
 5. Insert the bare end of the electrode in the electrode holder and hold the end of the electrode about 1 inch above the metal at the point where the weld is to be started.
 6. Turn the welder on.
 7. Lower the helmet over your eyes, bring the electrode in contact with the work and withdraw it slightly.
 - a. Current jumps this small gap creating the electric arc.
 - b. The moment the arc is struck the concentration of intense heat, estimated between 6,000 and 9,000 degrees F, melts the base metal and the end of the electrode forming a molten metal pool called a **crater**.
 8. There are two methods used in starting the arc.
 - a. A striking movement is similar to striking a match.
 - b. A tapping movement is where the electrode is quickly tapped on the surface of the metal to prevent it from sticking to the base metal.
 - c. If the electrode is not instantly pulled away it will fuse with the base metal and stick.
 - d. If the electrode is pulled too far away, the arc will be extinguished.
 9. Raise the tip of the electrode to about $\frac{3}{16}$ inch above the base metal. This forms a long arc which is held for a three count in order to preheat the base metal.
 10. Lower the electrode to the correct arc length.

- C. To make a wider bead or when doing out-of-position welding, use a motion of weaving or oscillating movements.
1. **Weaving** is running a bead with a sideways or oscillating motion. It is used when covering a wide area with weld metal or to maintain a large molten weld crater.
 2. **Padding** is the process of building up several layers of weld deposit by running overlapping passes. Padding is used to rebuild worn pieces by building up the piece to an oversized condition and grinding or machining to the correct size.
 3. These movements usually require more time and the beads are shorter per inch of electrode used.
- D. There are four positions used when welding: flat, horizontal, vertical, and overhead. The flat position produces welds that are stronger than in any other position.
- E. Controlling distortion, warping, and cracking is a major concern when welding due to forces that cause their shape or position to change.
1. During the welding process, the arc heats the area being welded, causing it to become larger, or expand. As heat is removed, the surrounding metal and air cause a cooling effect upon the heated area. This results in the metal becoming smaller or contracting. There is no way to avoid the laws of expansion and contraction.
 2. There are several methods that can be used to help control distortion.
 - a. Use a tack weld, where a short bead is placed at the edge of the end that you are welding to. The length of the tack weld should be twice the thickness of the base metal. Avoid over-welding by using as little weld metal as possible for the necessary strength.
 - b. Practice intermittent welding, where short beads are run, skipping spaces between them. Run short passes and allow them to cool before running the next pass.
 - c. Use the back step method, in which each short pass is started ahead and run back into the previous weld.
 - d. Balance the contraction of one bead by the contraction of another.
 - e. Carefully hammer or peen a weld deposit to stretch the weld and make up for contraction due to cooling.
 - f. Clamp material in a jig or to other rigid support during welding and cooling.
 - g. Preheat the materials being welded. Preheating makes welding easier and lessens the possibility of cracks.

Students can use the suggested resources to aid in understanding the content of the objective. Use TM-I, TM-J and TM-K to illustrate different beads, starting the arc, and moving the electrode. An alternative approach is to transfer the information from the transparency masters to a multimedia presentation.

Objective 5: Identify the safety practices that should be observed when working with shielded metal arc welding.

Anticipated Problem: What are the safety practices that should be observed when doing shielded metal arc welding?

- V. The following are suggested practices and tips that will help to eliminate shop accidents when arc welding.
- A. Wear a welding helmet. Wear leather or special fabric gloves at all times when arc welding to protect from hot electrodes, particles of spatter and slag, or the metal being welded.
 - B. Wear high-top shoes to protect your feet and ankles from burns caused by weld spatter. Do not wear clothing with turned up cuffs. Keep your collar and pockets buttoned. Do not wear ragged, oily or greasy clothing. Never weld when your body is exposed, as when not wearing a shirt, or wearing a short sleeved shirt or shorts. If leather clothing is not available, wear woolen clothing rather than cotton. Wool does not ignite as readily and provides better protection from heat.
 - C. Inspect welding cables for broken insulation and frayed conductors. Check electrode holder and ground clamps for positive connections before beginning to weld. Loose connections and grounds may prove dangerous. Provide a dry wooden platform to stand on or wear rubber soled shoes where there are damp floors.
 - D. Clear all combustible materials away from the welding area before beginning to weld. Flying sparks from the spatter may ignite combustible material several feet from the welding operation. Clear the welding area of rags, straw, paper, shavings, and other combustible items before starting to weld.
 - E. Keep matches, lighters, papers, and cellophane wrappers out of pockets as these items ignite quickly and/or may explode.
 - F. Turn on an exhaust system before beginning to weld. Welding fumes soon spread to all parts of the shop and may be injurious when inhaled. Take special measures to avoid noxious fumes that occur when welding or cutting metals containing zinc. Inhaling zinc fumes will cause you to feel ill for several hours after welding.
 - G. Do not strike an arc before covering face and eyes with the protective shield or helmet. The ultraviolet light rays given off by the arc are the same as those transmitted by sunlight, except that they are more intense and concentrated. Exposure to these rays will cause a severe burn. Eye irritation and burn will result if your eyes are not shielded.
 - H. Protect other workers by using a welding screen to enclose your area. Warn persons standing nearby, by saying “cover”, to cover their eyes when you are ready to strike an arc.
 - I. Never look directly at the arc without protecting your eyes. The rays can penetrate though closed eyelids if you are welding at close range. Do not wear contact lenses while welding or around a welder.

- J. Do not weld barrels, tanks or other containers which may have held combustible material. These operations are best performed by professional welders.
- K. Do not chip slag from a weld unless your eyes and those of others near you are protected by safety glasses.
- L. Be alert for fires at all times. Because the operator's helmet is lowered, and clothing may catch fire without being noticed. Depend on your senses of touch, smell, and hearing to indicate that something is wrong. In case of a clothing fire, strip off the article if possible. Do not run, as running fans the flames. Wrap yourself in a fire blanket, or improvise with a coat or a piece of canvas. If there is nothing at hand to wrap in, drop to the floor and roll slowly.
- M. Handle all hot metal with tongs or pliers to prevent burning your hands or gloves. Place all hot metal where no one will come in contact with it. Develop the habit of feeling all metal cautiously before picking it up. Do not leave hot metals where anyone may pick them up or step on them.
- N. Guard against saturation of clothing by perspiration or moisture. This increases the shock hazard.
- O. Disconnect the welder when repairing or adjusting it.
- P. Always unplug the welder and put all equipment away when you have finished for the day.
- Q. In case of eye or skin burns, get first-aid treatment. Report all burns and injuries immediately to the instructor.
- R. Protect fuel tanks and fuel lines with wet sheet asbestos when welding near motors or power units. Clean accumulations of dry trash, husks, lint, and chaff off of farm machinery before welding. The paint on machinery also may start to burn from the heat of welding.

Students can use the suggested resources to aid in understanding the content of the objective.

- **Review/Summary.** Focus the review and summary of the lesson around the student learning objectives. Call on the students to explain the content associated with each objective. Use their responses as the basis for determining any areas that need re-teaching. Questions at the end of each chapter in the recommended textbooks may also be used in the review/summary. Use the lab activities in reviewing and reinforcing student learning.
- **Application.** Application can involve the following student activity using the attached lab sheet. It is understood that before attempting the lab activities, proper safety precautions in the agriculture mechanics shop must be covered thoroughly.

◆ LS-A: Arc Welding Exercises

- **Evaluation.** Evaluation should focus on student achievement of the objectives for the lesson. Various techniques can be used, such as student performance, on the application activities. A sample written test is attached.

- **Answers to Sample Test:**

Part One: Matching

1 = i, 2 = e, 3 = j, 4 = g, 5 = b, 6 = h, 7 = d, 8 = f, 9 = c, 10 = a

Part Two: Completion

1. direct current (DC)
2. padding
3. Arc length
4. 1.5, 2
5. thickness, diameter
6. alternating current (AC)
7. Resistance
8. weaving

Part Three: Short Answer

1. Amp setting, arc length, angle of electrode, speed travel.
2. Protects molten metal from the atmosphere, mixes with weld metal and floats impurities to the top, stabilize the arc.

Applying Shielded Metal Arc Welding (SMAW) Techniques

► Part One: Matching

Instructions. Match the term with the correct response. Write the letter of the term by the definition.

- | | |
|----------------|---------------|
| a. arc length | f. polarity |
| b. arc welding | g. resistance |
| c. duty cycle | h. welder |
| d. electricity | i. welding |
| e. electrode | j. weldor |

- ____ 1. Melting, flowing together and freezing of metals under controlled conditions.
- ____ 2. Bare metal rod.
- ____ 3. Person doing the welding.
- ____ 4. Opposition to the flow of current in a circuit.
- ____ 5. Uses electricity to heat and melt the metal.
- ____ 6. Machine doing the welding.
- ____ 7. Flow of tiny particles called electrons through a conductor.
- ____ 8. Direction the current is flowing.
- ____ 9. Percentage of a 10 minute period that a welder can operate at a given current setting.
- ____ 10. Distance from the tip of the bare end of the electrode to the base metal.

► Part Two: Completion

Instructions. Provide the word or words to complete the following statements.

1. Electron flow in one direction is called _____.
2. The process of building up several layers of weld deposit by running overlapping passes is known as _____.
3. _____ is equal to the diameter of the bare end of the electrode.

COMPONENTS OF AN ARC WELDING SYSTEM

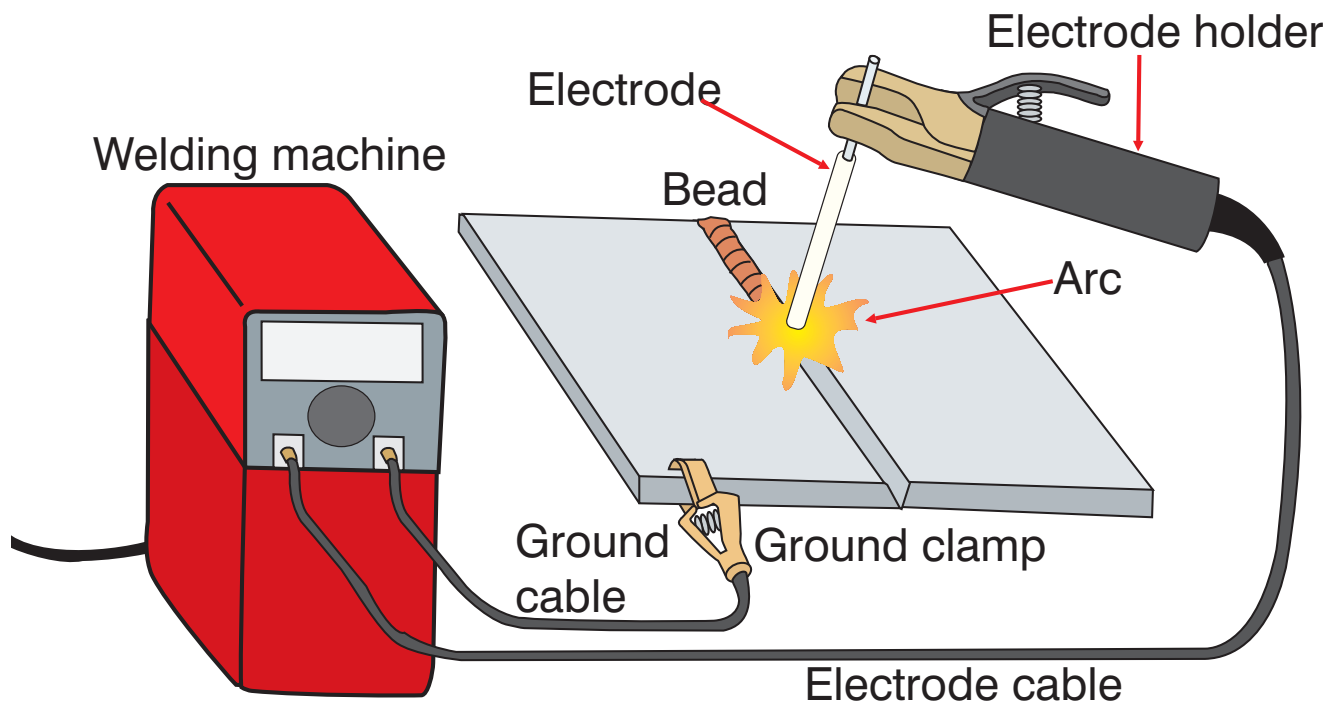

AC AND DC CURRENT

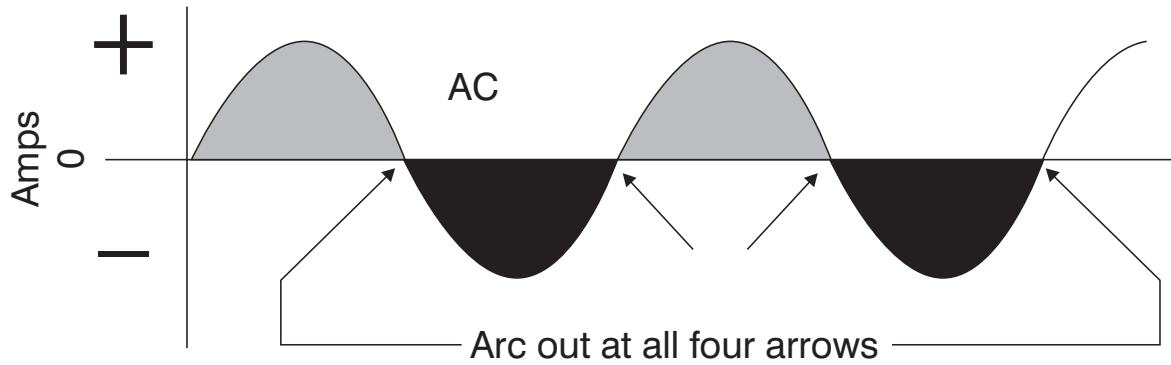

The arc is extinguished every half-cycle in AC welding.

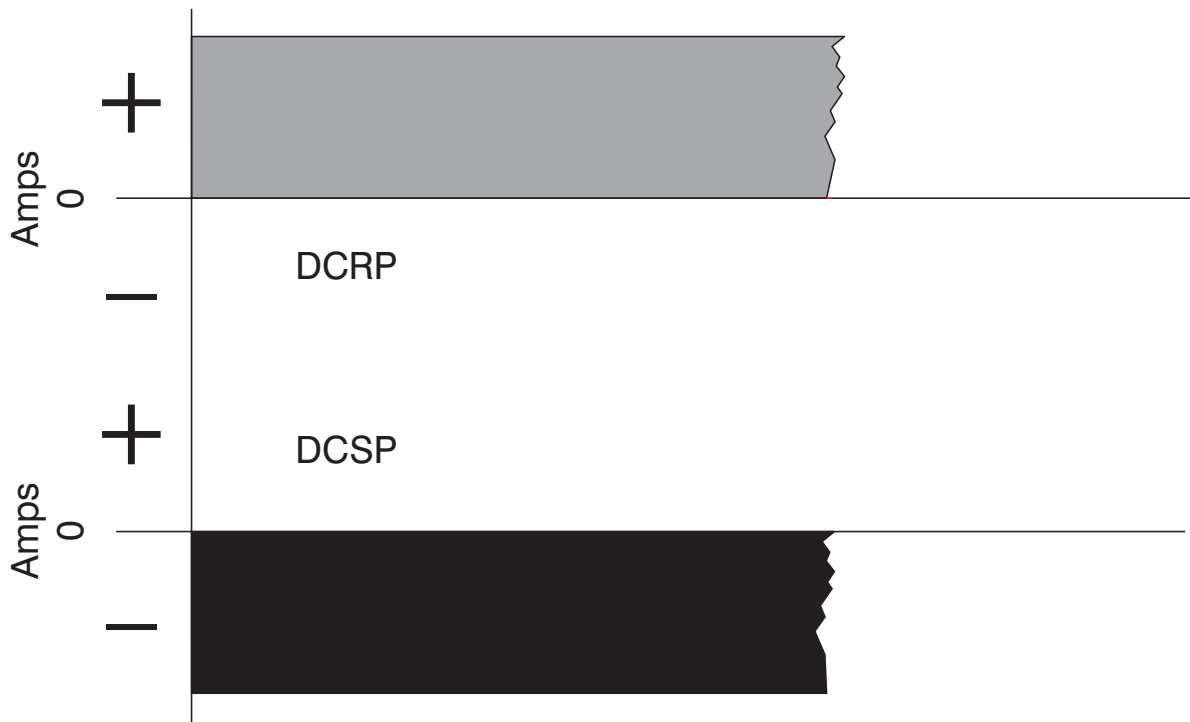

Current flow for reverse and straight polarity

SHIELDED METAL ARC WELDING

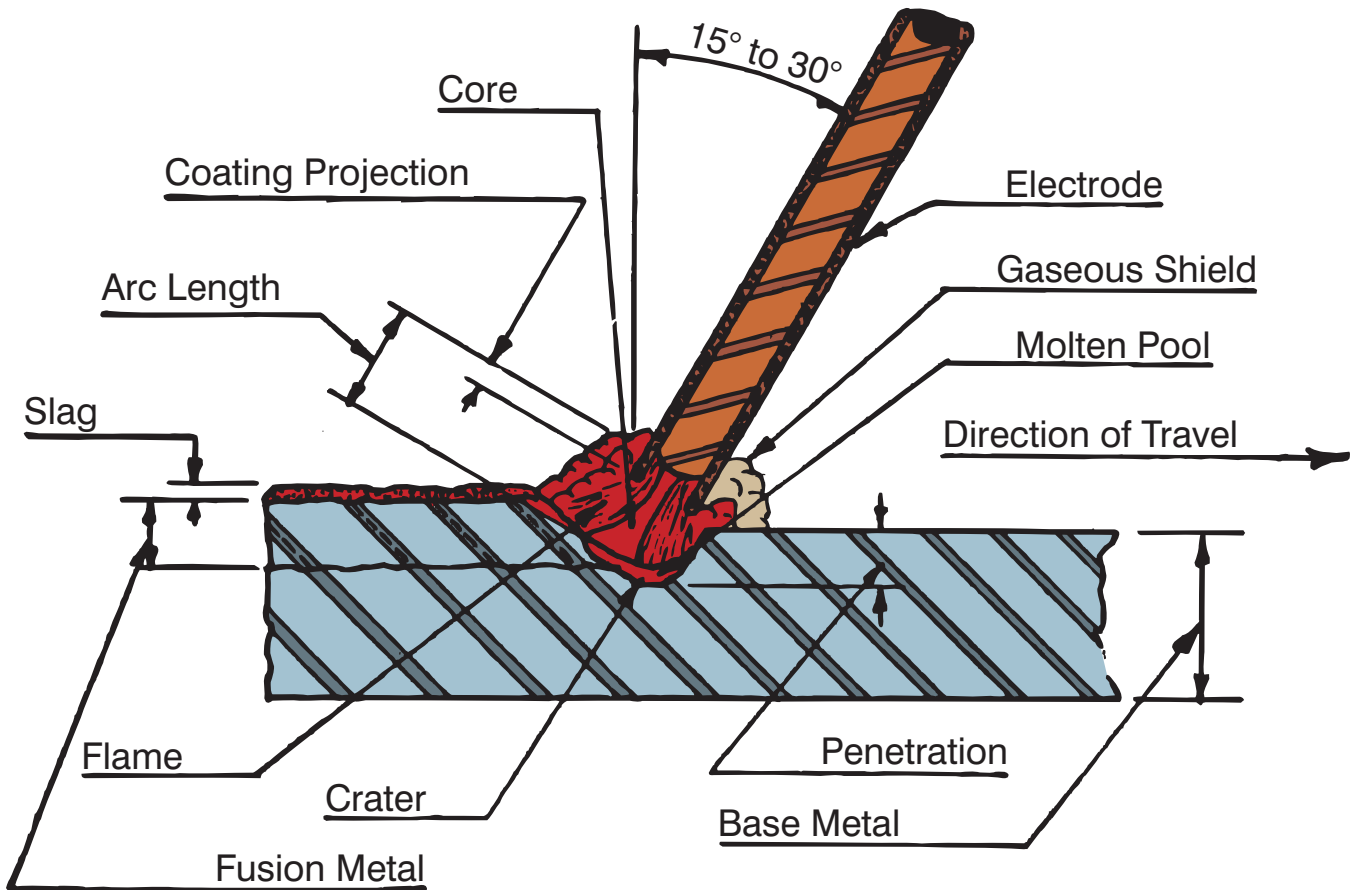

COMMON WELDS

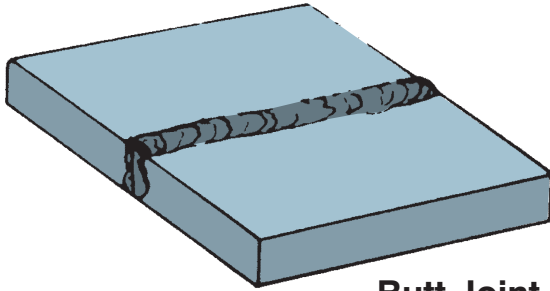

Butt Joint

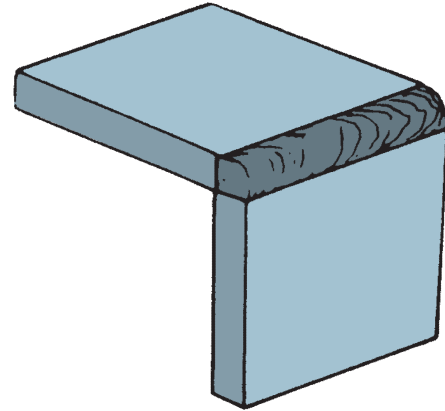

Corner Joint

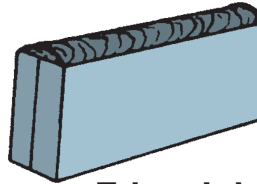

Edge Joint

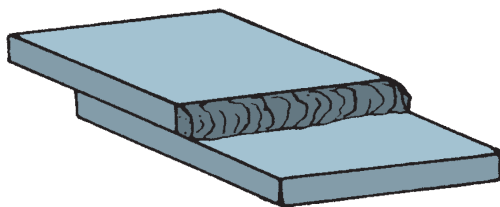

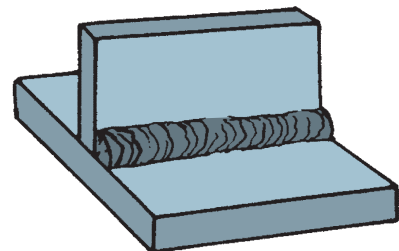

Lap Joint

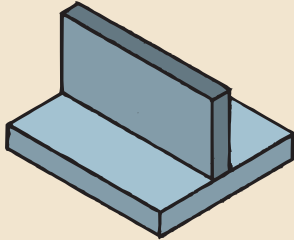

Tee (Fillet) Joint

MAJOR TYPES OF WELDS

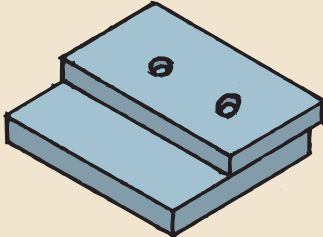
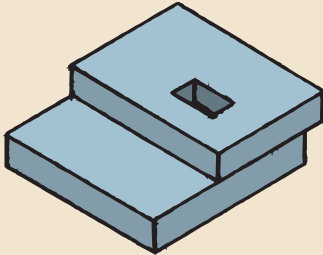
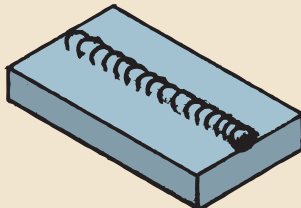
Major Types of Welds	Example	Other Common Joints
Fillet		Tee Lap
Groove		Single V Double V Single Bevel Double Bevel Single U Double U
Plug		Single J Double J
Slot		
Surfacing		

BASIC WELDING POSITIONS

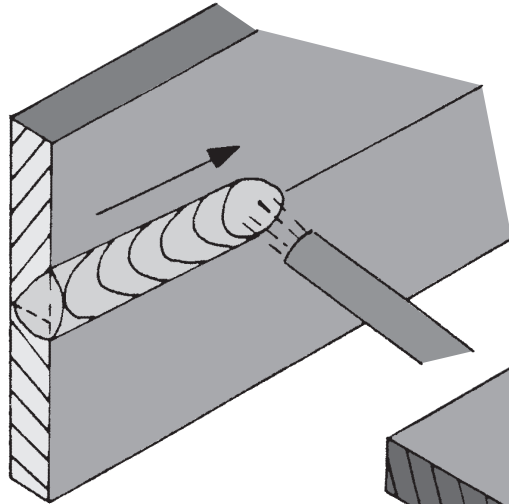

Horizontal

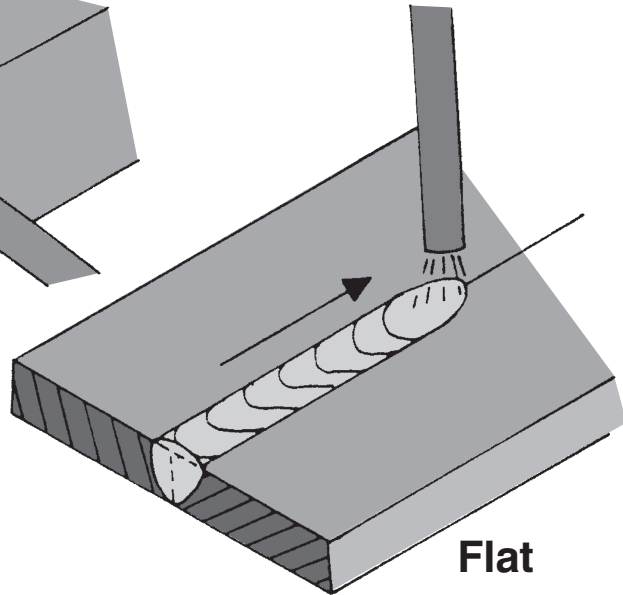

Flat

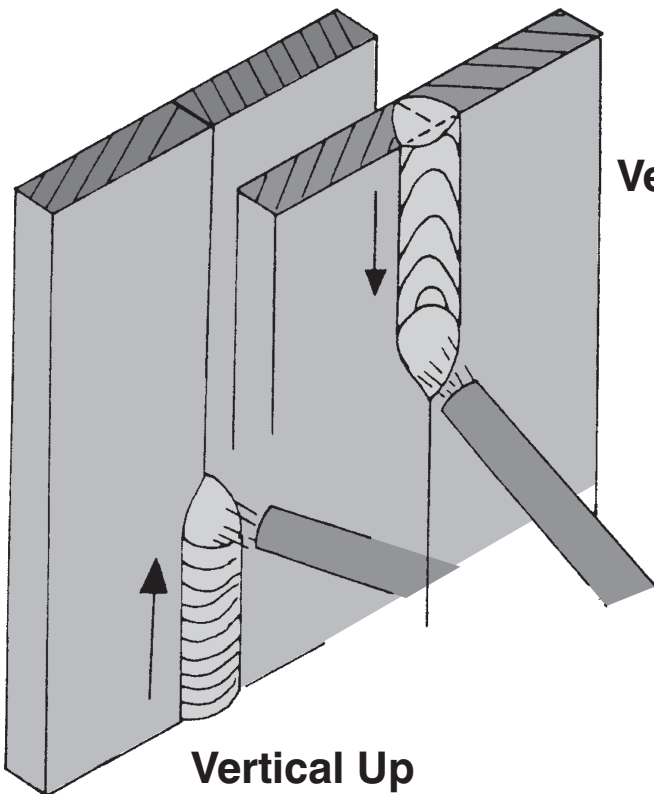

Vertical Down

Vertical Up

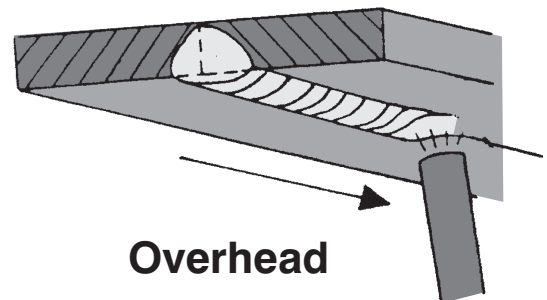

Overhead

COMMON JOINTS USED IN WELDING

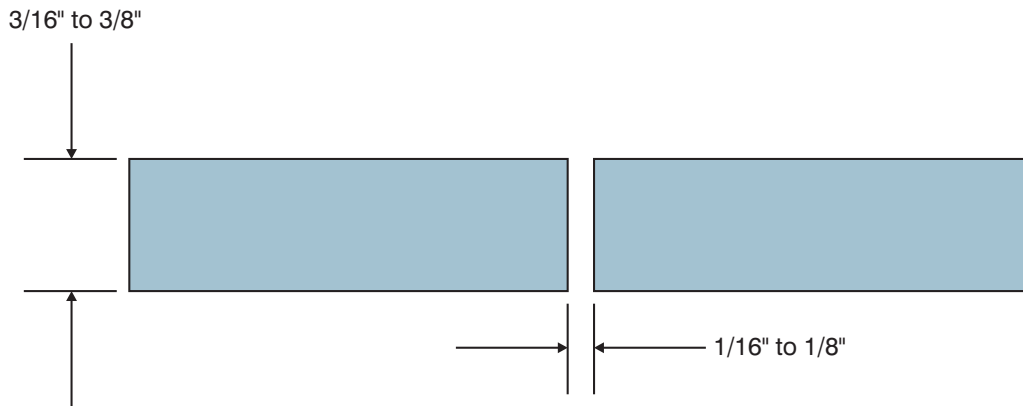

Square butt joint with a 1/16" to 1/8" root gap.

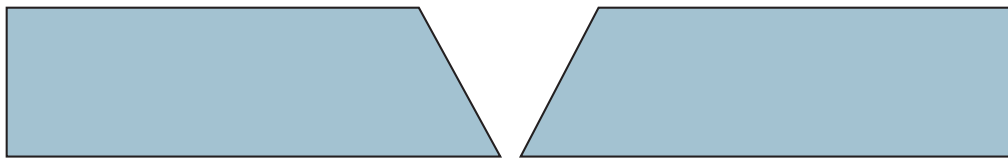

Single-V butt joint.

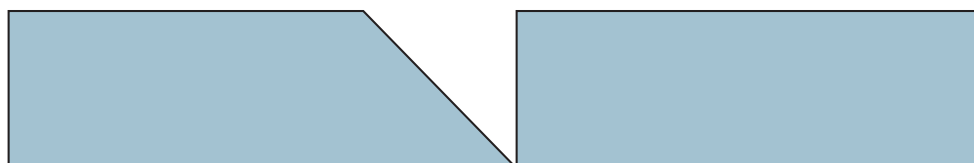

Single-bevel butt joint.

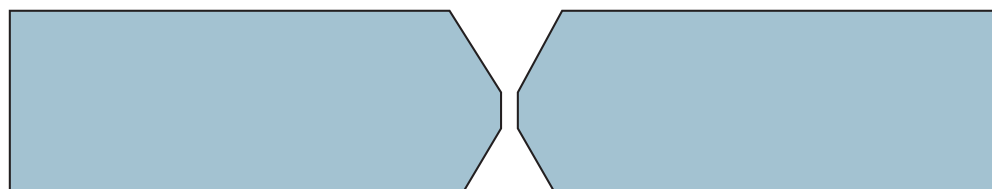

Double-V butt joint.

COMMON JOINTS USED IN WELDING (CONTINUED)

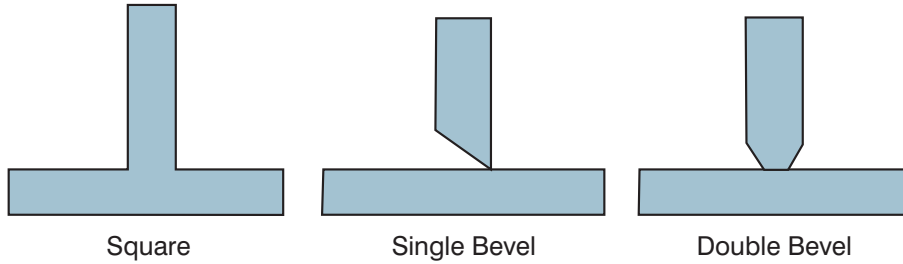

TYPES OF FILLET WELDS

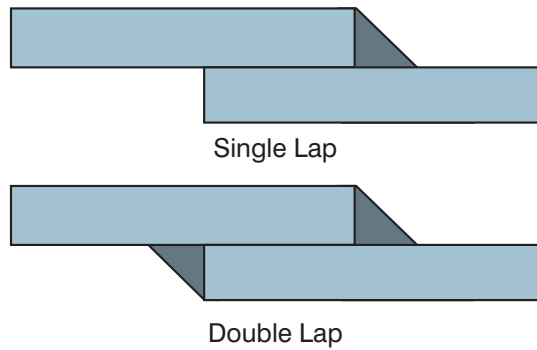

LAP JOINTS

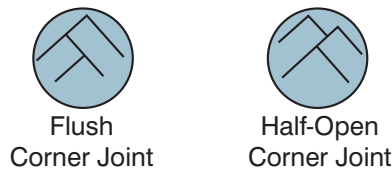
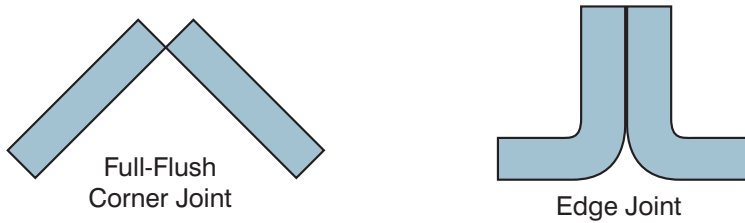

CORNER AND EDGE JOINTS

BEAD COMPARISON

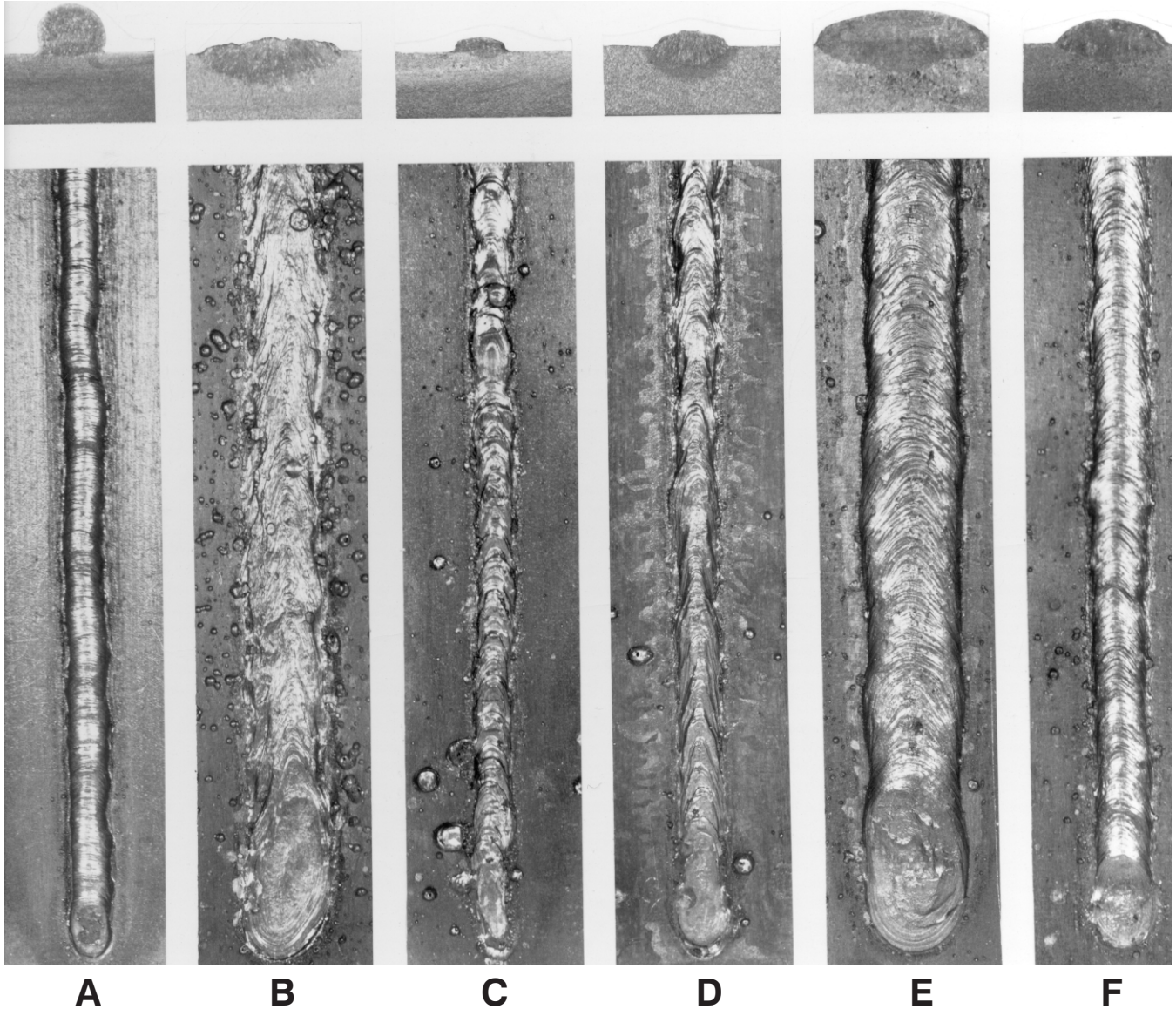

A. Welding current too low.

B. Welding current too high.

C. Arc too long.

D. Welding speed too fast.

E. Welding speed too slow.

F. Proper amperage, voltage, and speed.

METHODS OF STARTING THE ARC

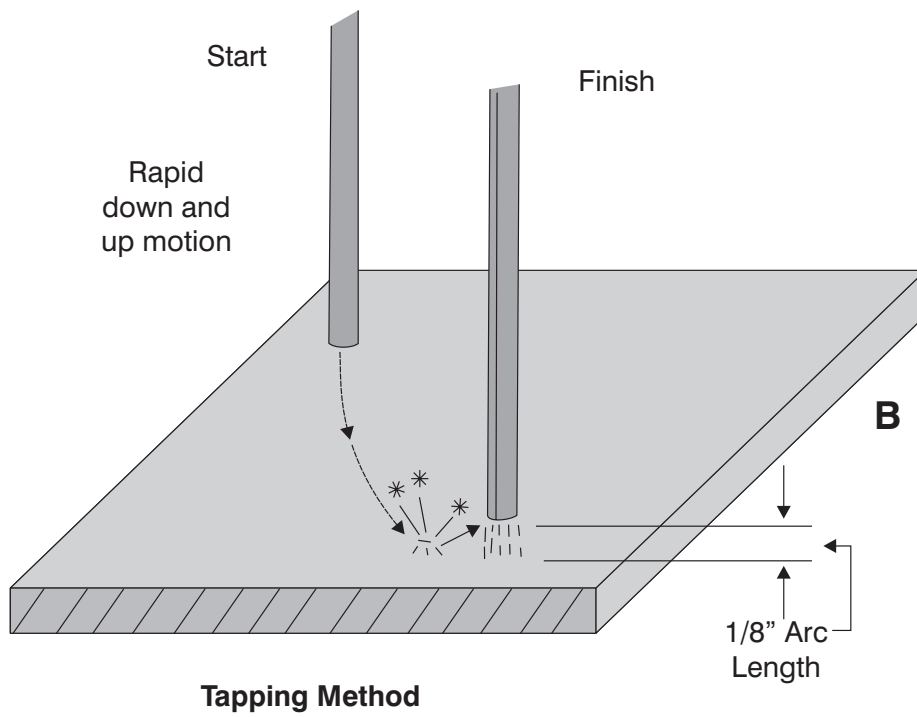
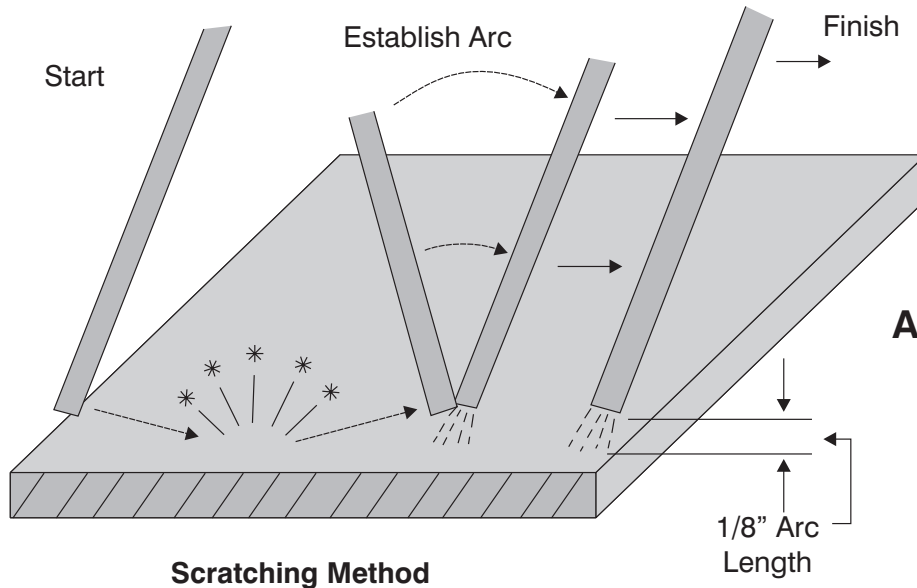

ELECTRODE MOVEMENT



Whipping Motion

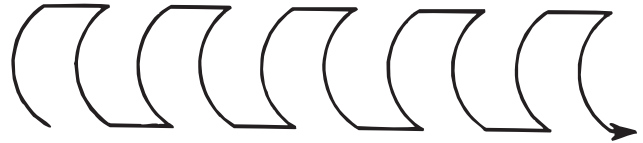

"U"-Shaped Motion



Back and Forth, or "N" Motion

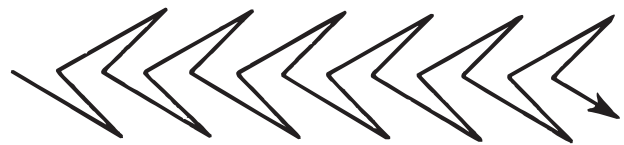

"V"-Shaped Motion



Semicircular Motion

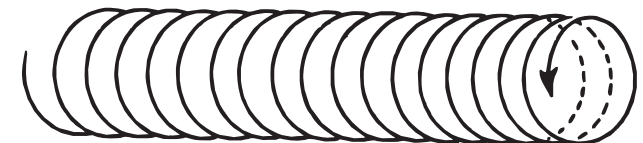

Circular Motion

Arc Welding Exercises

Complete the following lab exercises in the order shown. A lab sheet should accompany each exercise. Before moving to the next exercise, gain instructor approval and directions.

- #2 6011 Butt Weld #5 6013 Bead #8 6013 Tee (Fillet) Weld
- #3 6011 Lap Weld #6 6013 Butt Weld

1. Type of weld and lab exercise no.: _____
2. Welding position: _____
3. Type and size of rod used: _____
4. Type and thickness of base metal: _____
5. Current setting: _____

6. SCORECARD:

a. General appearance (smooth, uniform ripples)	5	4	3	2	1	0
b. Width (uniform)	5	4	3	2	1	0
c. Height (uniform)	5	4	3	2	1	0
d. Penetration	5	4	3	2	1	0
e. Starting	5	4	3	2	1	0
f. Stopping	5	4	3	2	1	0
g. Safety procedures followed	5	4	3	2	1	0
h. Other	5	4	3	2	1	0
i. TOTAL POINTS EARNED	_____					

7. Comments: _____

8. Grading scale	36—40	A- to A+
	32—35	B- to B+
	28—31	C- to C+
	24—27	D- to D+
	1—23	F
	0	0